

Quickstart Guide

1. Intended Use

Thank you for purchasing the Setra FLEX, the industry's most advanced and flexible room environmental monitor.

Setra FLEX is designed for indoor use only to monitor critical environments by providing differential pressure indication and additional parameters such as temperature, relative humidity, air changes per hour, and user-defined information. Typically this is between a monitored room and a reference space such as a corridor or ante room. The unit also provides monitoring, control, alarm, and communications functions.

Typical Applications:

1. Hospitals – patient isolation and protection rooms, operating suites, intensive care and emergency rooms.
2. Pharmaceutical, semiconductor, precision manufacturing and clean rooms
3. Laboratories – medical research, BSL (bio safety labs), radiation, vivarium, toxic metals and chemicals.

Included in the box

- a) FLEX unit
- b) FLEX unit mounting screws
- c) Tubing
- d) Room pressure snubber (RPS, if ordered) and mounting screws
- e) Electrical connector kit

Quantity of box contents may vary.

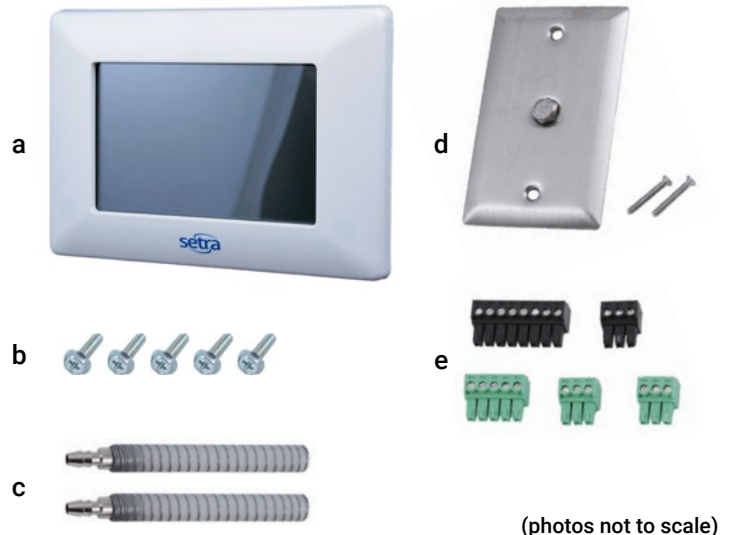

Parts required and to be supplied by installer

To mount and install properly, the following components are required.

NOT INCLUDED and required for each FLEX unit:

- Triple Gang Double Deep Metal Electrical Box, RACO 697 or Appleton M3-350 or equivalent: 1
(a single-deep box may be used if no on-board pressure sensor was ordered)
- Green grounding screw: 1
- Power and signal wiring, as needed
- ¼" pressure tubing to run from the room(s) to the FLEX unit
- Transformer, 24 VAC
- Door Switch SPDT or SPST, N.O., as needed
- Remote Pressure Transducers, as needed
- Remote Annunciators, as needed

2. Wiring

Inputs & Outputs

Universal inputs (3)	0-5 VDC, 0-10 VDC, or 4-20 mA input signal* Configurable for either Analog or Digital signals. Use external sensors for pressure, temperature, humidity, or any suitable application. Use as digital input for door, HVAC filter DP, or duct static DP pressure switch.
Analog input (1)	Dedicated for use as input for either on-board pressure transducer, or general AI input. Used only when no transducer is purchased on unit.
Analog output (1)	0-5 VDC, 0-10 VDC, or 4-20 mA output signal. Use as PI control loop to modulate reheat valves or other analog driven devices, pressure output signal, or mirror an input signal. Can be assigned to any room parameter.
Relay output (1)	24 VDC SPDT NO/NC Relay. Use as remote alarm annunciator or other NO/NC applications. Contact rating 2.0A @ 30 VDC /VA 0.6A @125 VAC
Wire	Stranded shielded twisted pair, 16-24 AWG .14-1.5 mm ² cross sectional area
Expansion I/O module	8 Universal Inputs, 4 Analog Outputs, 4 Relay Outputs

*Installer provided 250Ω resistor required for 4-20mA signal

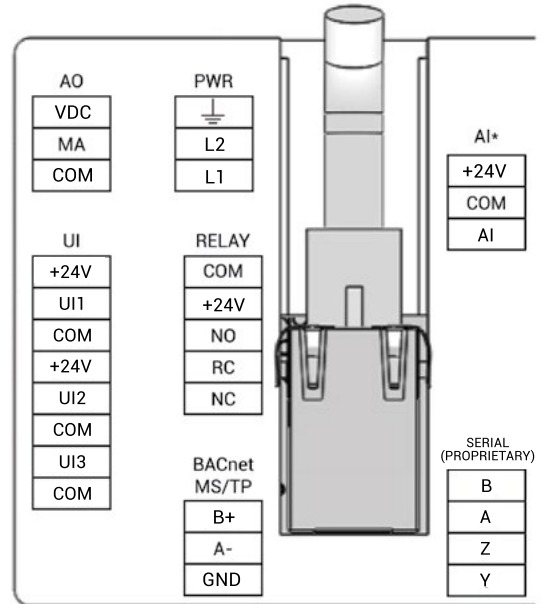

3. Rough-In

- Ensure rough-in box is ready to receive the RPS
 - Setra RPS Reference Pressure Side
 - 1-Gang Electric Box
 - Setra RPS Room Pressure Side
 - Setra FLEX Unit (Display hinges down during installation then snaps in place when mounting is complete)
 - Setra FLEX Unit (may be mounted inside or outside room)
 - Wall cavity
 - Electrical Box (3-Gang double-deep if using on-board sensor, single deep if no on-board sensor)
- Ensure rough-in box is ready to receive the FLEX unit

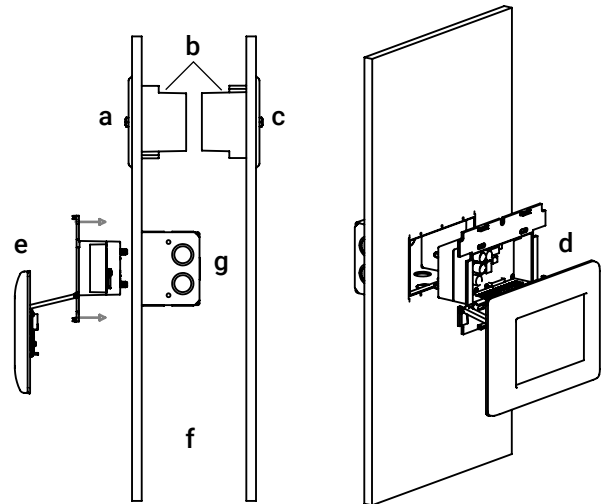

4. Installation

- Make the final connections by pushing the removable connectors and wires into the back of the FLEX unit. If connecting BACnet/IP, insert the RJ-45 cable into the Ethernet port. If connecting pressure tubing, align HIGH and LOW ports to their appropriate pressure sensor connections with anti-kink tubing and secure in place.

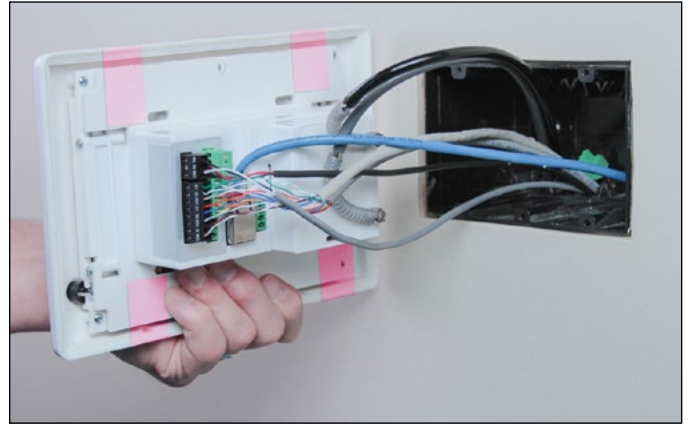

- Slide the FLEX unit back into the wall, taking care to not crimp tubing or damage wires.



- Secure the FLEX base unit into the electrical box with the four (4) mounting screws provided. Allow the FLEX display to hang below the mounting box, taking care so that the display does not get damaged by tools.

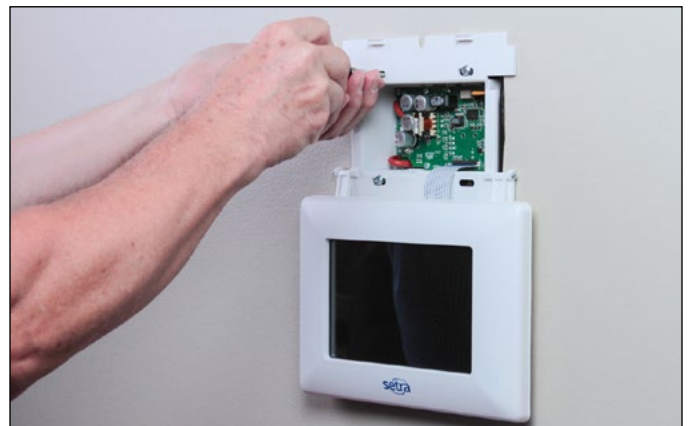

- BACnet MS/TP hardware is implemented as isolated RS485. Wire to Connector COMM, labeled BACNET. Connect TX line to B (+), RX to A (-) and ground wires to GND. Connect shields together with wire nut. Hardware configuration is done using a three position dip switch located in the upper center section of the rear PCB. Use a small flat blade screwdriver or pen to push the switch to the right to turn the function on, or to the left to turn the function off. If the unit will be at the end of the line, the pull up resistor can be enabled by pushing position 1 to on.

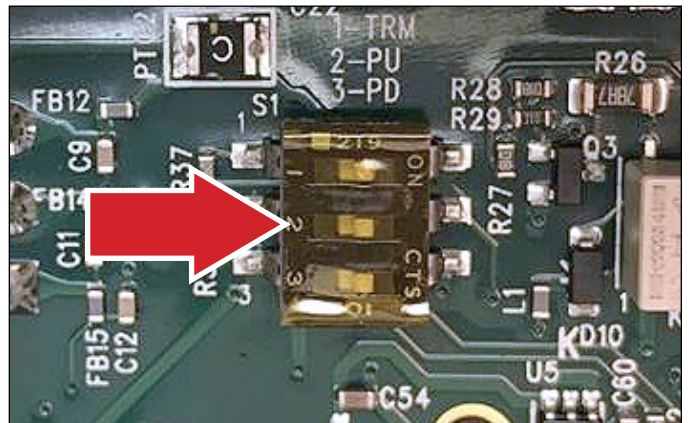

- With the FLEX display hanging open and unit powered, re-zero the sensor to ensure accurate operation:
 1. Remove one end of each pressure tube (shown here)
 2. Access "Settings" > "Maintenance" > "Pressure Calibration"
 3. With tubes disconnected, press "Adjust Zero"
 4. Reconnect tubes
- The unit is now ready for final mounting

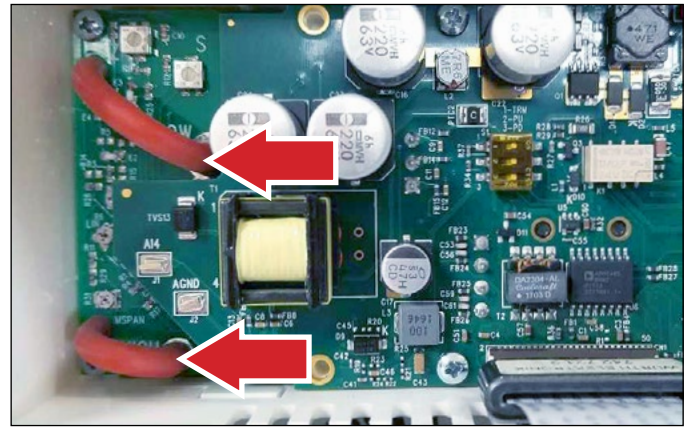

- If live power is already turning on FLEX, power can be removed from FLEX by removing the J6 jumper on the unit. This can be done by hand, or carefully with non-conductive pliers. Normally, FLEX is continuously powered and this jumper does not need to be accessed.

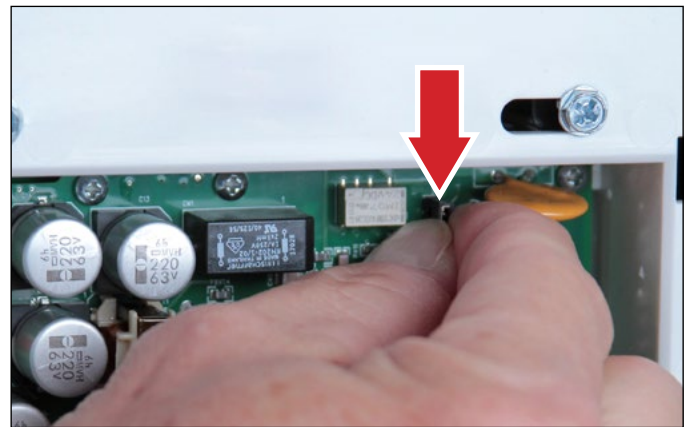

- Swivel up the FLEX display, and push firmly at the frame just above and just below the touch screen. The display will snap into place and seal against the wall surface.

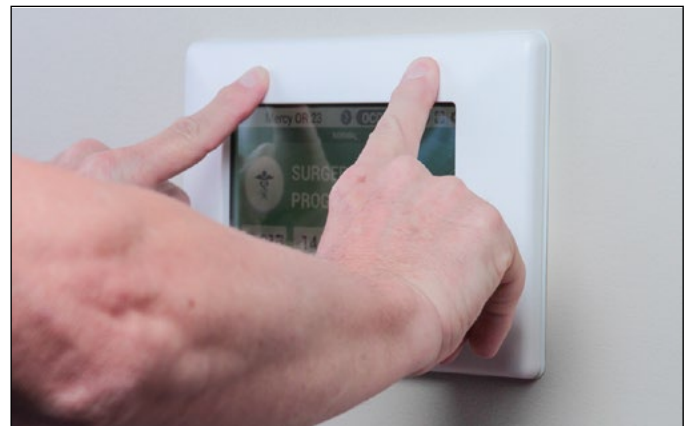

5. Power Up Configuration

- Access the "cog wheel" on the top-right of the FLEX display to configure the unit.

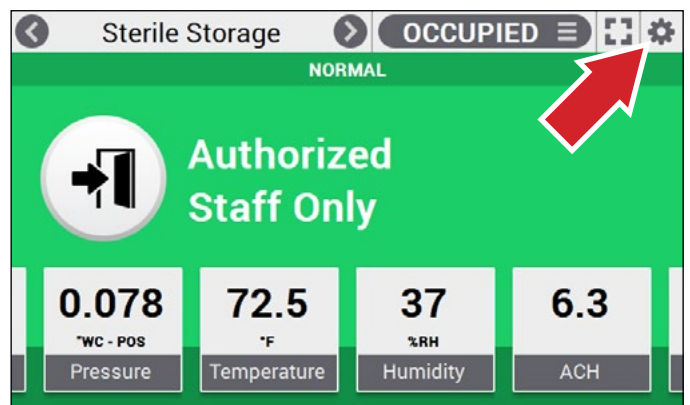

- Use "Device Configuration" for initial setup.

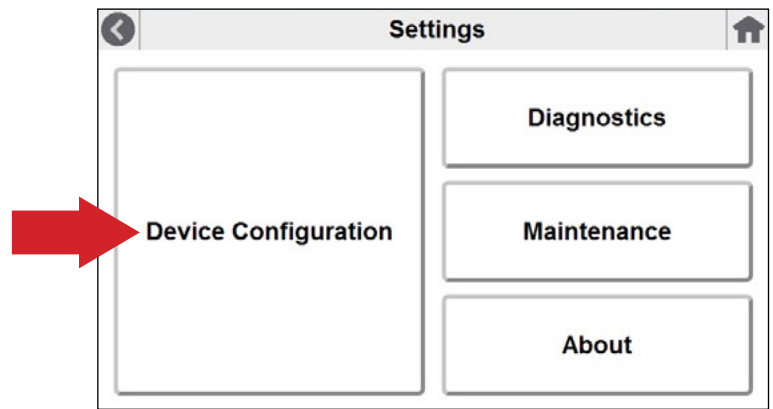

- The next seven menus (three tiles over four) permit complete configuration of your FLEX unit. Detailed instructions for each menu can be found in the FLEX Installation & Operations Guide.

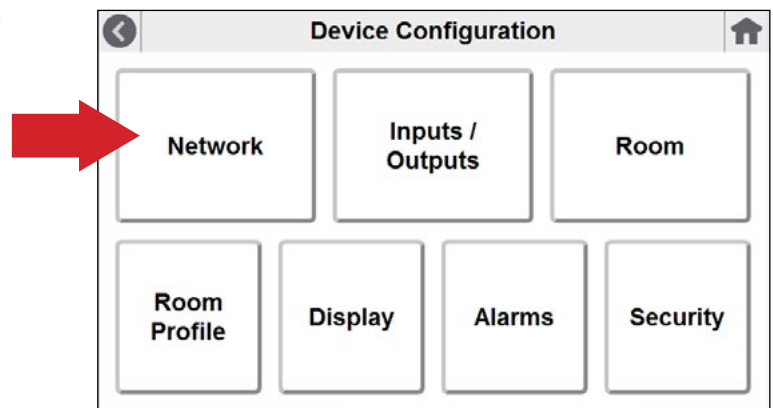

6. FLEX Home Screen

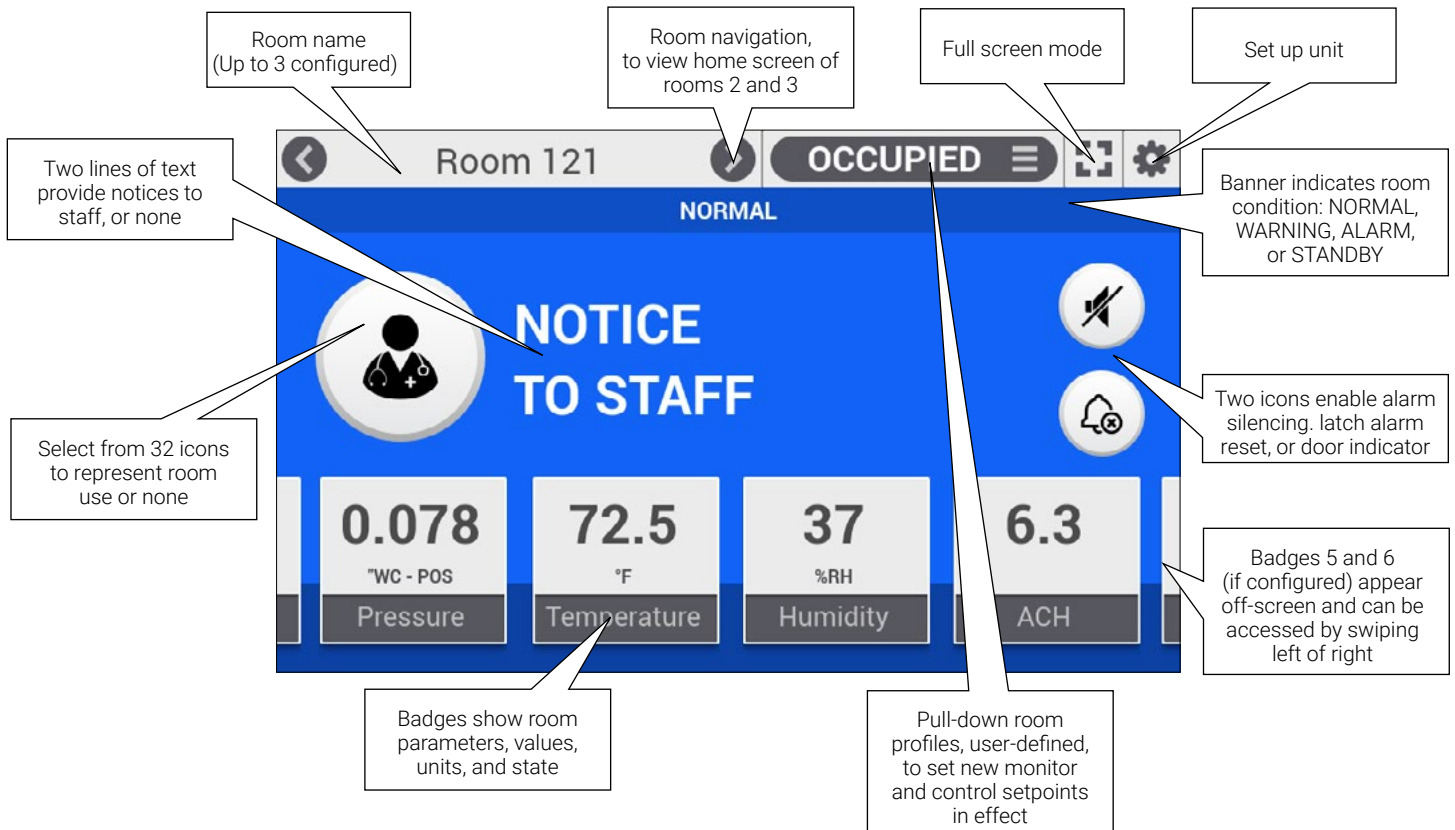

7. Specifications

Physical Description

Dimensions	9.25" W x 6.3" H x 0.65"D (215.0mm x 160.0mm x 16.51mm)
Mounting	Triple-gang, double deep electrical box. RACO 697, Appleton M3-350, or equivalent
Case	Fire-retardant plastic UL94 V-0
Weight	2 lbs
Display	7" Projected Capacitive (PCAP) multitouch. 800 x 480 pixels. Usable with medical gloves.
Display brightness	1-7
USB port	Micro-USB port for configuration cloning between units and software upgrades.
Audible alarm	Dual piezo with 3 volume levels (0-75 dB max.)

Communications

Protocols (BACnet objects can be found at setra.com)

BACnet/IP using IPv4, Ethernet CAT5 cables with RJ45
BACnet MS/TP up to 76.8 kbps, 3-conductor, twisted, shielded 16-24 AWG cable

Electrical

Power	24 VAC (18-32 VAC operational), 50-60 HZ
Power draw	13 W max, 10 W typical
Wire	2 or 3-conductor (depending on application) stranded unshielded twisted pair, 16-24 AWG
Connections	Removable Terminal Blocks

Regulatory Compliance

CE, RoHS, WEEE

Specifications subject to change without notice.

Environmental Data

Operating temp. °F (°C)	32 to 120 (0 to 50)
Storage temp. °F (°C)	-40 to 185 (-40 to 85)
Operating humidity	5 to 95% RH (non-condensing)
Ingress Protection (IP) rating	IP54

Chemical Resistance

Exposed surfaces are chemically resistant to vaporized hydrogen peroxide (VHP), formaldehyde, chlorine dioxide (clidox), perchloric acid, sodium hypochlorite 3-6% (bleach), quaternary ammonium 7% in 1:128 tap water (ammonia).

Performance

Accuracy RSS	±0.25%
Non-linearity (BFSL)	±0.24%
Hysteresis	±0.05%
Non-repeatability	±0.05%
Span setting tol.	±0.5% Rdg
Zero/span shift % FS	± 0.03% PSI (±0.05% FS)
Overpressure	±1 PSI (15" WC for ≤0.10" WC FS)
Pressure media	Air or non-conductive, non-explosive gases
Pressure fittings	3/16" barbed fittings
Altitude	6562 ft. (2000 m) max.
Position	Housing to be 90° in reference to level surface, ±5°

8. Maintenance

- The FLEX is designed to operate in an indoor environment, monitoring clean, dry air.
- Upon final installation of the FLEX Environmental Monitor, no routine maintenance is required. An annual check of system calibration is recommended. FLEX is not field serviceable and should be returned if repair is needed (field repair should not be attempted and may void warranty). Be sure to include a brief description of the problem plus any relevant application notes. Contact customer service to receive a return goods authorization number before shipping.
- **WARNING:** Do not blow into the pressure tubing or fittings with mouth, compressed air, or canned air. Such actions may permanently damage the pressure sensor. Do not clean or wash-down FLEX with industrial cleaners or solvents other than those approved in specifications. Do not immerse unit.